

Preliminary Design of a 7 kW_e Free-Piston Stirling Engine with Rotary Generator Output

James G. Wood , Neill W. Lane and William T. Beale
Sunpower, Inc.
Athens, Ohio, USA
www.sunpower.com

Abstract

A preliminary design for a linear motion free-piston Stirling engine / blower coupled to a rotary turbine / generator is described. The design combines several features of prototype free-piston machines that are nearing commercial production. This approach promises to extend the commercially practical range of free-piston Stirling engine / electric generators. The Stirling driver is comprised of two conventional, displacer type, free-piston engines configured as a dynamically balanced opposed pair. Using the outer face of its power piston, each engine drives a single-acting blower. The single turbine / generator uses commercial units and is separate from the engines and connected by ductwork. The engines and turbines utilize the same helium working fluid.

Introduction

During the 1990's, Sunpower prototype free-piston Stirling machines (engines, coolers, and cryocoolers) accumulated thousands of hours of maintenance free operation and tens of thousands of stop-start cycles.^{1, 2, 3} Free-piston (linear) compressor designs are also proving reliable as well as efficient, and are nearing commercial availability.⁴ This work proposes a design that builds on these maturing technologies. This design promises to increase the feasible electric output of generators based on free-piston Stirling engines (FPSE).

Free-piston Stirling engine/alternators made at Sunpower typically include a linear alternator within the engine pressure vessel.⁵ This configuration is appropriate for modest electrical power, and scales well from <100 We to 10 kWe. A 25 kWe FPSE / generator of this configuration was designed in the early 1990's but not built. Larger sizes as single units are feasible but unlikely to be commercially viable, as alternator volumes become excessive. A solution long recognized⁶ but not as yet put into practice is the coupling of the free-piston engine to a pump and turbine. This paper presents a design for coupling free-piston Stirling engines to a rotary turbine / generator.

General System Description

The Stirling driver is comprised of two conventional, displacer type, free-piston engines configured as a dynamically balanced opposed pair. Each engine drives a simple single-acting blower (or low pressure ratio gas pump), using the outer end of its power piston. The single turbine / generator is separate from the engines and connected by ductwork. The engines and turbines utilize the same helium working fluid. This arrangement is shown schematically in Figure 1.

Both the engine / blowers and the turbine / generator are hermetically sealed within pressure vessels. The engine / blower design incorporates well-proven elements previously used in other free-piston Stirling machines^{1,2,3,5} and in linear compressors.⁴ The engine / blower opposed pair arrangement exploits the intrinsic reliability of non-contact sliding surfaces provided by gas bearings, and the absence of unbalanced forces or side loads.

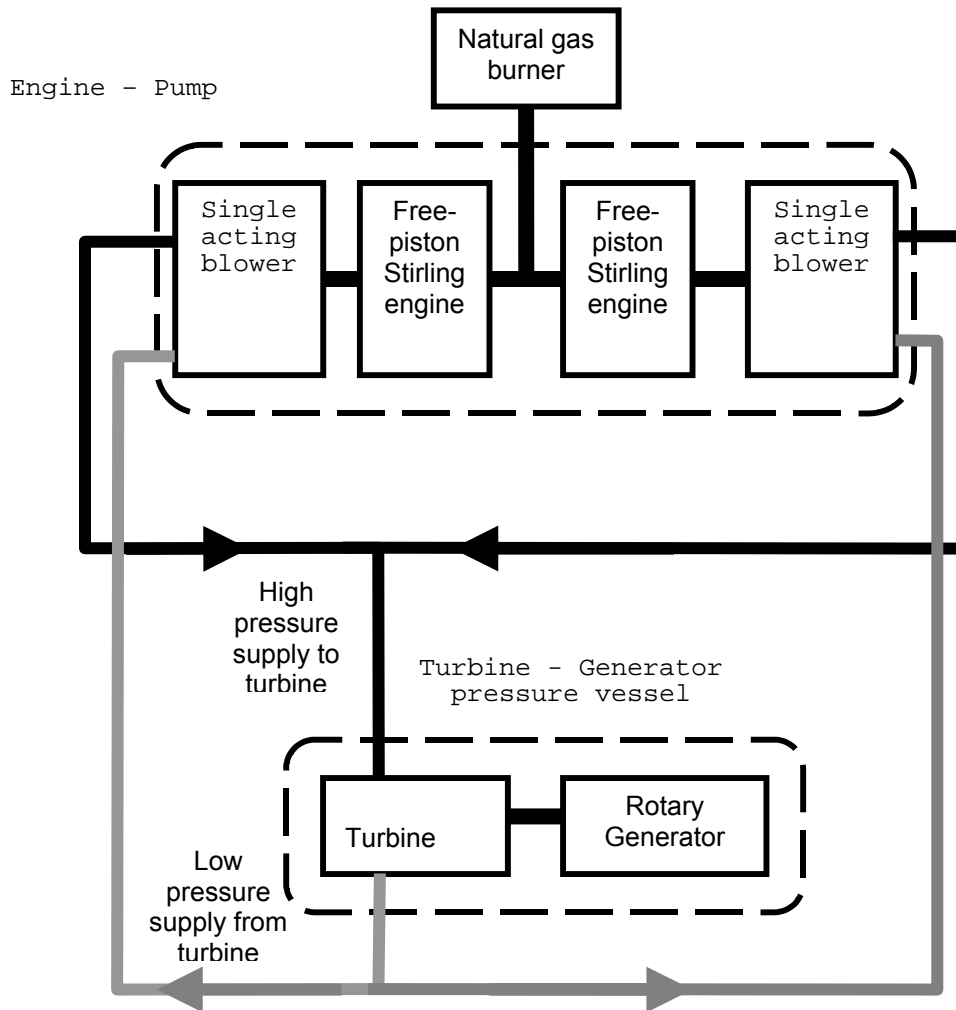

Figure 1. System Schematic

The design requirements of the system presented are as follows:

- 7 kW_e output
- Continuous duty
- Stationary
- Natural gas fueled
- One to two year maintenance cycle
- Fit in 0.6 X 0.6 X 1.1 m volume
- Mass not to exceed 115 kg
- 40,000 hr life
- Low emissions
- Low vibration
- Low noise

Engine – blower

Engine overall design. A schematic of one half of the Stirling driver is shown in Figure 2. The engine is based loosely on an existing engine design⁷ with relatively minor changes to the volume variations and phasing, as well as to the heat exchangers. For mechanical simplicity, the pump cavity is located at the back-end of the constant diameter piston. Further simplification is possible because the piston mass is reduced compared to machines with a linear alternator, and the pistons can be resonated entirely by the working space pressure swing. Mechanical springs are therefore not required. To minimize pump complexity and sealing requirements, the displacer is resonated by a double acting gas spring within the body of the displacer. Back-end mechanical springs and the associated flexures to resonate the displacer are therefore not required. Instead, to minimize pressure-driven hysteresis losses in the gas spring, we selected two low-pressure ratio gas springs, each having a large effective area, as shown in Figure 2.

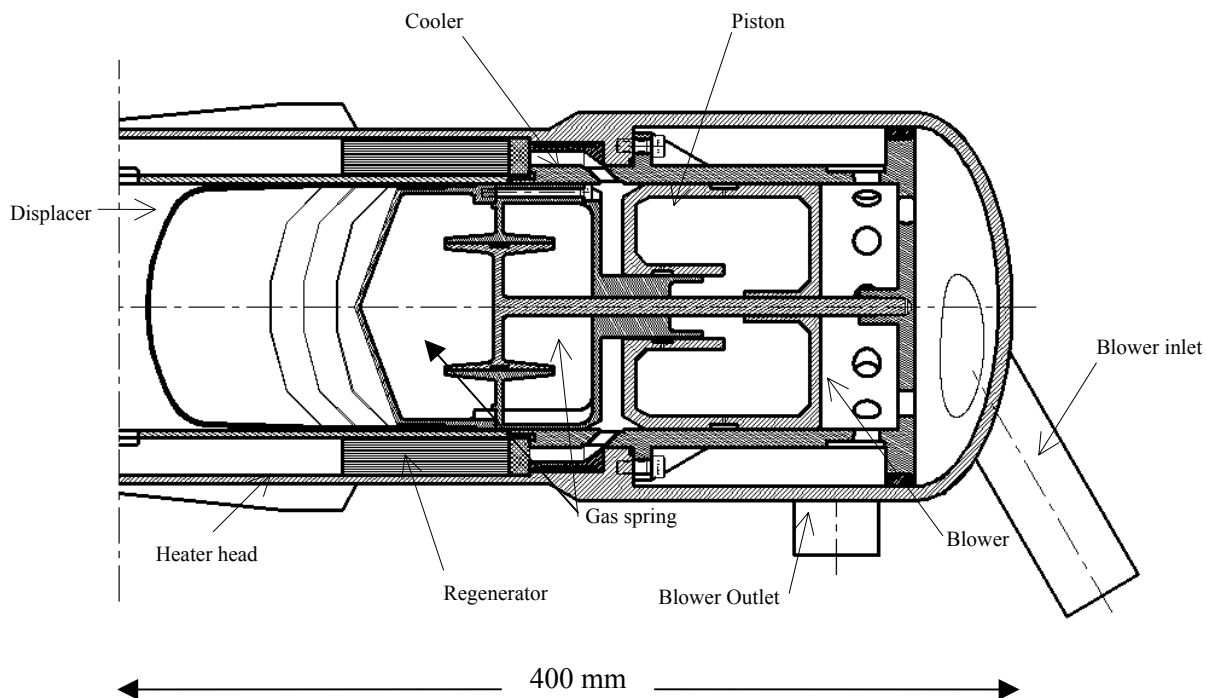

Figure 2. Single engine and blower (from opposed pair)

Balance. Within a single pressure vessel, free-piston Stirling machines can be configured as opposed pairs, with a shared expansion space. When this is done, the two machines operate in phase, and vibration forces are cancelled. For example, the Stirling Orbital Refrigerator/Freezer (SOR/F) on board the U.S. Space Shuttle *Discovery* mission in 1994 was operated throughout the mission⁸ since its opposed design eliminated net force transmission to its mounting. For the present design, the elimination of vibration from the engine-pump components facilitates the burner and ductwork design and greatly reduces the generation of noise from component and auxiliary vibrations.

Burner. A recuperative burner using natural gas as fuel is proposed. The recuperator is a conventional finned counter-flow heat exchanger (Figure 3). Castable ceramics are used for the burner parts exposed to high temperature. This burner is an adaptation of an existing design and can be adapted to use other gaseous or liquid fossil fuels.

Heater head. The heater head is a monolithic design, being a simple cylinder with external axial fins. This design is compatible with the cylindrical recuperative burner shown in Figure 3. The thermal and pressure stresses in this single tube design are significantly easier to address than in a design in which the end of the expansion space is enclosed. This proposed design has no critical braze or weld joints and the internal copper fins are thermally attached to the head wall using a braze joint that is not required to seal the working fluid.

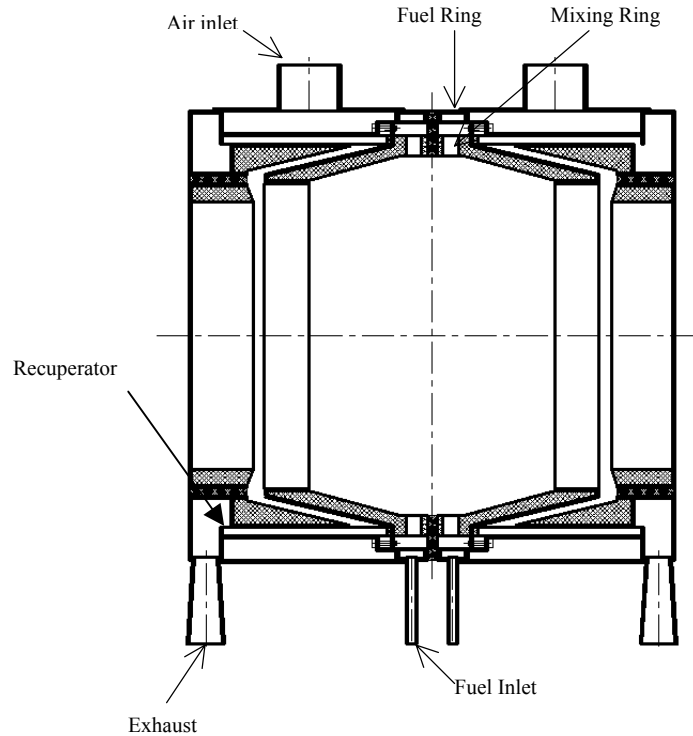

Figure 3. Burner layout

Gas bearings. The piston and displacer float on hydrostatic gas bearings that eliminate contact and wear, and promise essentially infinite life. These gas bearings are pressurized using the pressure swing from the compression space through a check valve and do not require a dedicated pump. The same gas bearings have been well proven in previously designed engines, coolers and compressors, some of which have to date operated for over 45,000 hours³ and 600,000 stop-start cycles.⁹

Engine components. The internal components of the Stirling engine (heat exchangers, bearings, piston and displacer and their associated drive elements) are conventional designs that have been demonstrated in similar engines driving linear alternators. The internal heat exchangers for the cooler and heater are densely compressed copper fins attached to the wall by braze in the heater and by solder in the cooler. These heat exchangers avoid the large number of critical joints of tubular heat exchangers. An annular gap foil regenerator is used.

Blower. Sunpower's in-house linear compressor proprietary design code was used to design the single acting blowers. The important design parameters are presented in Table 1. The blower pump was sized using Sunpower's standard technique for the initial sizing of linear compressors and the results are given below.

Swept volume	245 cm ³
--------------	---------------------

Mass flow rate	91x10 ⁻³ kg/s
Volumetric flow rate	0.55 m ³ /s
PV power	4.87 kW
Compression ratio	1.087
Mean Pressure	4.49 MPa

Table 1. Design parameters for blower

The blower is a simple, low-pressure ratio, single-acting pump blower, sized to absorb the engine power and deliver the required flow volume and pressure to the turbine. The design is conventional and the valves are typical of those used in Sunpower-designed compressors for refrigeration and for lubrication-free gas compression. From the experience derived from these other prototypes, these valves are expected to have very long life. Since the blower pressure ratio is very low (less than 1.1), it is essential to minimize flow losses in the blower and ductwork.

Turbine / generator

Turbine. While a turbine could be located within the pressure vessel of the engine, a more flexible arrangement is to mount the turbine nearby, connected by ductwork. This arrangement allows independent selection of the turbine-alternator without modification of the engine, and allows the option of ganging a group of engines to drive a single turbine-alternator if higher power is desired at a later time.

The design requirement can be met by many configurations of the turbine. Commercial sources recommend variants of radial inflow turbines since they are already widely used in internal combustion engine turbochargers and are available in standard, well-proven designs. Preliminary scaling indicates that the turbine would run in the 30,000-50,000-rpm range, have a 50 to 60 mm impeller, and efficiency in the 85% range.

Generator. The generator component can be integrated with the turbine and enclosed in the same pressure vessel, using gas bearings for long life. These gas bearings can be pressurized hydrodynamically using the rotation of the shaft, or hydrostatically by pickup of high-pressure supply from the Stirling engine blower. A 30,000-rpm alternator (90 V) of the correct power would be approximately 53 mm long and 94 mm in diameter.

Stirling Engine: Simulated Performance and System Energy Flows

The engine design has been simulated using Sunpower's proprietary linear simulation code, SAUCE. This tool has been used to design numerous Stirling coolers and engines over the last 10 years in sizes from fractions of a watt to 25 kW. SAUCE solves both the dynamic and thermodynamic equations involved in the design of free-piston Stirling machines and includes a full loss inventory. The inclusion of these losses is essential to modeling a real machine.

The net output of the system is 7 kW_e and the system energy flows, with estimated component efficiencies at the design point, are given in Figure 4. A map of the simulated engine performance is shown in Figure 5.

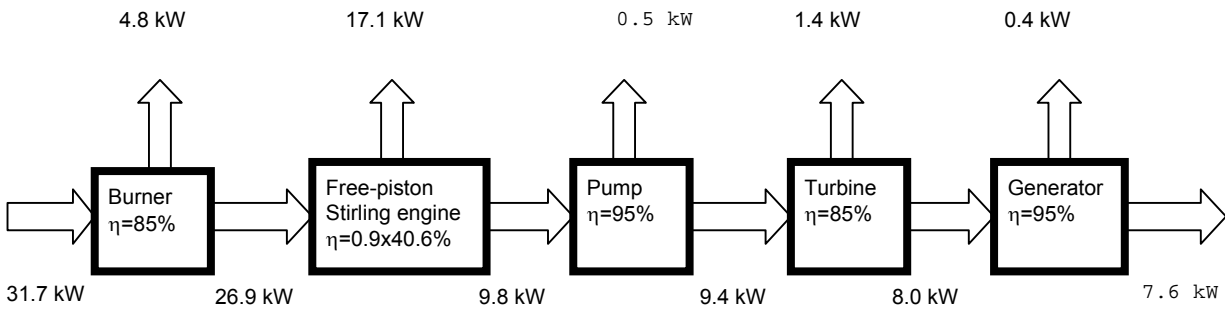

Figure 4. Design point system energy flows

Power control.

Power control is accomplished by variation in the size of the turbine nozzle. The engine sees the result as a change in pressure loading on the blower, which causes a change in piston amplitude at approximately constant engine efficiency (Figure 5). The system efficiency under partial load is therefore determined mostly by the turbine response to variation in gas flow rate. The pressure ratio across the turbine can be approximately invariant with load as a result of the engine response to flow by change of amplitude.

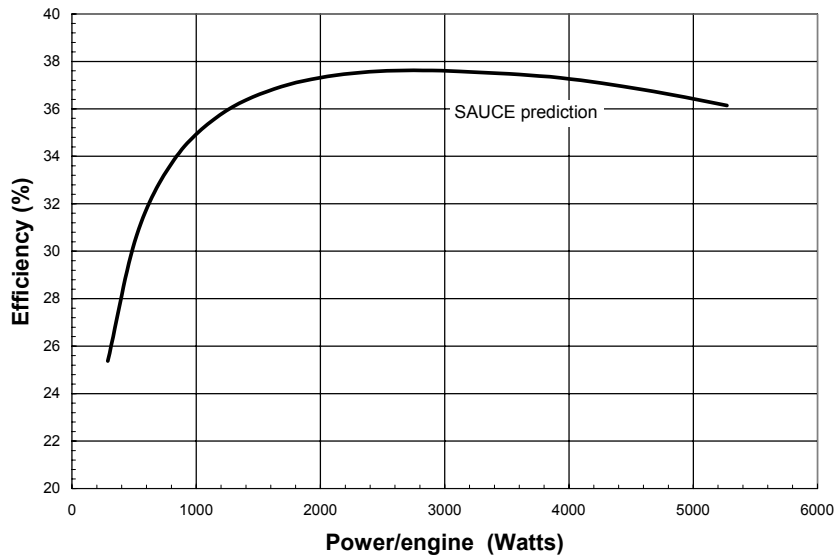

Figure 5. Simulated single engine performance at various powers

Engine Layout

An annotated layout of the single engine and blower is shown in Figure 2. Figure 6 shows the complete opposed pair of engines and blowers with the heater head located in the central area of the machine. The total engine-blower pair length is 815 mm and the mass is estimated at 70 kg.

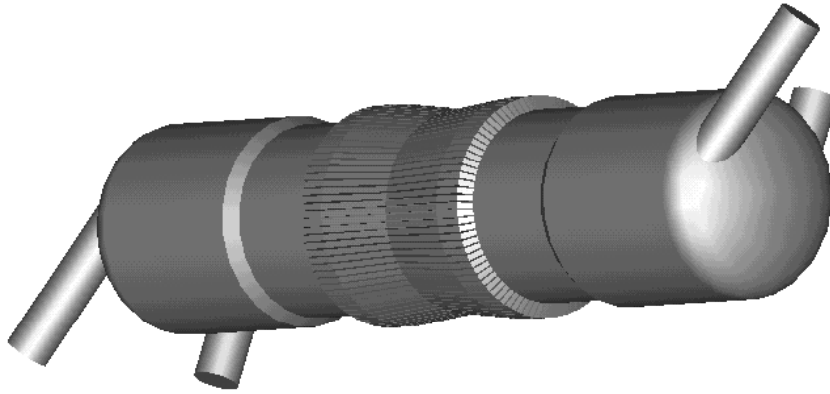

Figure 6. Opposed engine / blower pair with burner

Future Work

Other possibilities to improve this preliminary design can include the following options:

- double-acting 3 or 4-cylinder free-piston with turbine-alternator
- using the pumped helium loop of the turbine to reject the engine waste heat
- power boosting by combustion heating of turbine inlet gas
- turbine mounting within engine pressure vessel
- double acting blower
- high temperature alloy hot-end heat-exchanger for highest system efficiency
- high frequency Stirling engine to reduce mass and size¹⁰

Summary

A design for combining linear free piston Stirling engines to a conventional rotary alternator is presented. The design is modular and uses one or more opposed engine pairs to eliminate engine vibration. The advantage of this design lies in its application at higher power ranges where linear compressors become bulky and massive.

Acknowledgments. The authors thank Meg Hummon for editorial support.

¹ Karandikar, A. and D. Berchowitz. Low Cost Cryocoolers for Commercial Applications. Cryogenic Engineering Conference, Columbus, Ohio, July 17-21, 1995. USA. Proceedings published in Advances in Cryogenic Engineering, Vol. 41.

² <http://hessi.ssl.berkeley.edu/instrument/cryocooler.html>

³ Unger, R.Z., R.B. Wiseman and M.R. Hummon. The Advent of Low Cost Cryocoolers. 11th International Cryocooler Conference (ICC11), Keystone Colorado, June 20-22, 2000. Proceedings published in Cryocoolers 11, Kluwer Academic/Plenum Publishers.

⁴ Lee, H-k, G-y Song, J-S Park, W-h Hong, W-h Jung, and K-b Park. Development of the Linear Compressor for a Household Refrigerator. Proceedings of the Fifteenth International Compressor Engineering Conference at Purdue University, West Lafayette, Indiana, USA, July 25-28, 2000, pp. 31-39.

⁵ Lane, N.W., and W.T. Beale. Free-Piston Stirling Design Features. Presented at Eighth International

Stirling Engine Conference, May 27-30, 1997, University of Ancona, Italy.

- ⁶ Beale, W.T. Free-Piston Stirling Engines – Some Model Tests and Simulations. International Automotive Engineering Congress, Detroit, Michigan, January 13-17, 1969. (SAE 690230)
- ⁷ Lane, N.W. and W.T. Beale. Micro-Biomass Electric Power Generation. Presented at Third Biomass Conference of the Americas, August 24-29, 1997, Montreal, Quebec, Canada.
- ⁸ McDonald, K., D. Berchowitz, J. Rosenfeld, and J. Lindemuth. Stirling Refrigerator for Space Shuttle Experiments. Proceedings of the 28th Intersociety Energy Conversion Engineering Conference (IECEC), Monterey, California, August 7-11, 1994.
- ⁹ Personal communication from Sunpower customer.
- ¹⁰ Lane, N.W., D.M. Berchowitz, D.Shade and A. Karandikar. Development of a High Frequency Stirling Engine-Powered 3 kW(e) Generator Set. Proceedings of the 24th International Energy Conversion Engineering Conference, 5:2213-2218 (IECEC 899156). New York: Institute of Electrical and Electronics Engineers.